

Date code  
YY = year  
WW = week

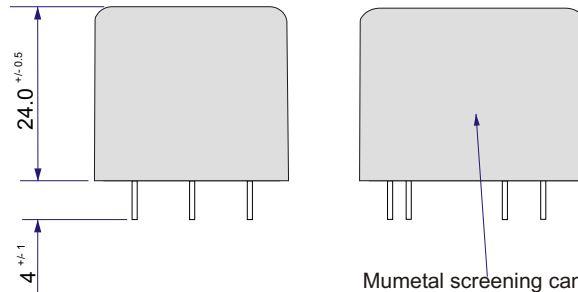

Mumetal screening can

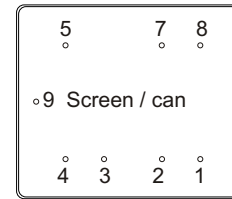

Pin view

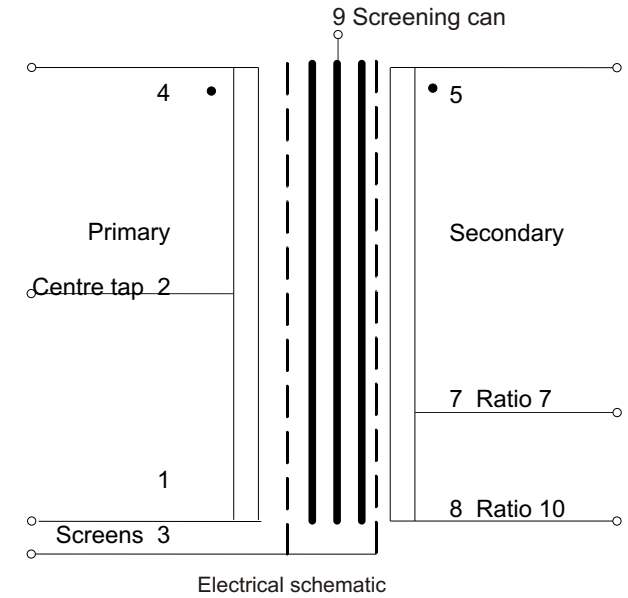

Electrical schematic

**Electrical characteristics:**

Turns ratio: 1 C.T. to 7 or 10

Input impedance range: 3 to 100

Output (primary loaded with 100 ): 19.2k

Voltage gain (-20dBu ,1kHz):19.48dBu (typ.)

Maximum input @ 20Hz for <1% THD: -4.6dBu

DC resistance ( +/-15%)

(4 - 1): 19.6

(5 - 8): 647

Leakage inductance @ 3kHz, 0.1V

(5 - 8): 38mH (typ.) (1, 2 & 3 S/C)

Interwinding capacitance @ 10kHz

(4 - 1) to (5 - 8): 157pF typ.

(4 - 1) to (5 - 8): 28pF typ. with screens and can earthed

(4 - 1) to screen: 255pF typ.

(5 - 8) to screen: 255pF typ.

**Features:**

- Matching low impedance moving coil phono cartridges to transistor or valve pre-amps
- Multiple electrostatic screens
- Encapsulated in a mu-metal screening can that provides up to 30dB of magnetic shielding

**Proof voltages**

Primary to secondary: 250VDC

Windings to screens: 250VDC

Operating temperature range: 0 to +70°C

Storage temperature range: -25°C to +120°C

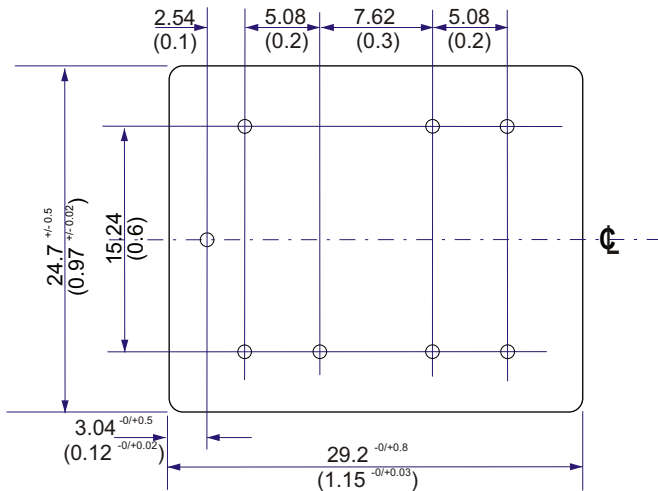

Tolerance on all dimensions in mm: +/- 0.1 unless stated otherwise.  
Inches shown in brackets.  
Tolerance on dimensions in inches: +/- 0.005" unless stated otherwise.  
Pin diameter 0.7mm (0.0276)

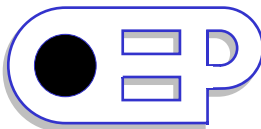

Unit 5, Oxonian Park, Langford Locks,  
Kidlington, Oxfordshire. OX5 1FP  
Tel: (01865) 855085 Fax: (01865) 855075  
Website: [www.carnhill.co.uk](http://www.carnhill.co.uk)



Scale: N.A.

**DESCRIPTION**

Specification for A187A16C/1  
page 1 of 2

All dimensions in mm unless stated otherwise

ISSUE	DATE	DRAWN	CHECKED	DRAWING NUMBER
1	05/02/13	CS		<b>A187A16C/1</b>
6	22/03/17	CS		
7	08/01/19	CS		
8	08/02/24	CS		

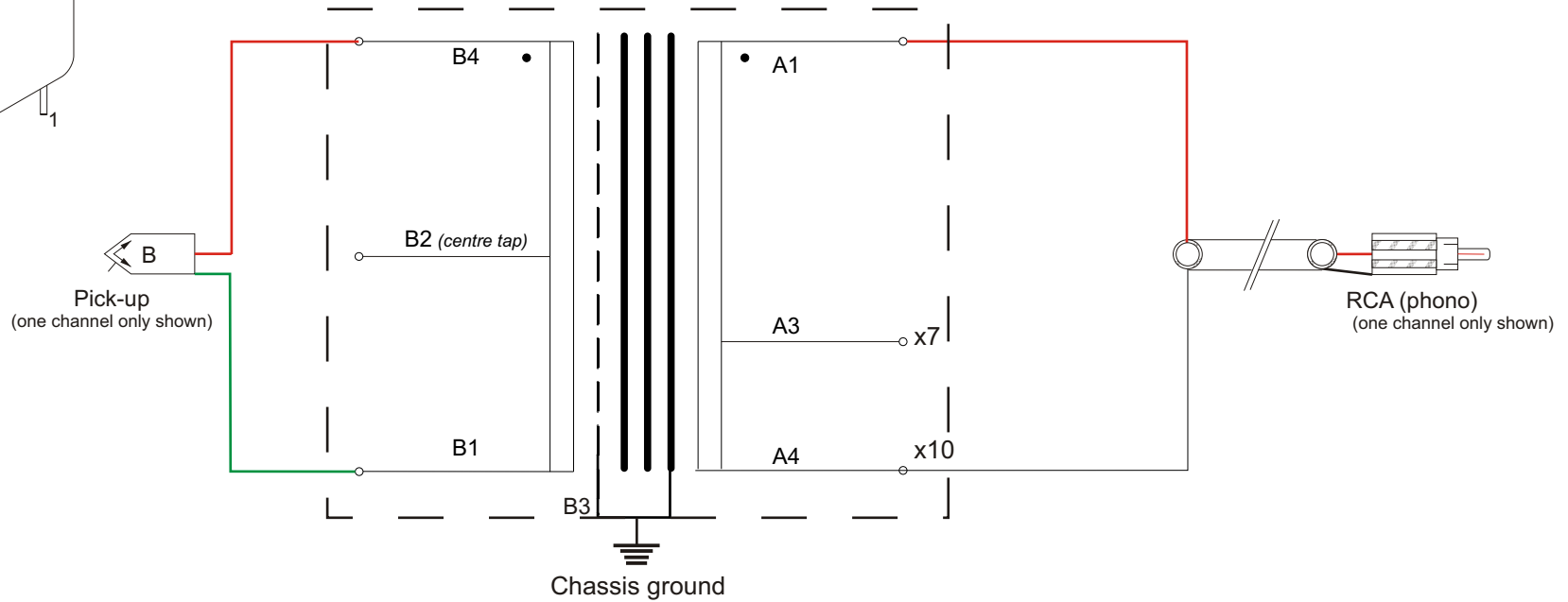
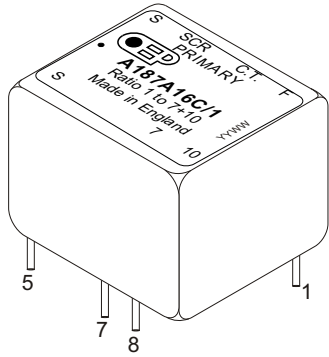

**Notes:**

- Ground screen (B3) and screening can.
- Do not connect input and outputs to chassis ground
- Unused pins should be left floating with minimal pad size for best performance.
- All leads should be as short as possible.
- Pick-up leads should be twisted tightly.
- Two transformers are required for stereo
- Lead colours should be checked with cartridge manufacturer

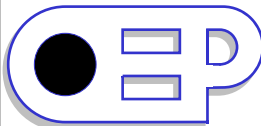

Unit 5, Oxonian Park, Langford Locks,  
Kidlington, Oxfordshire. OX5 1FP  
Tel: (01865) 855085 Fax: (01865) 855075  
Website: [www.carnhill.co.uk](http://www.carnhill.co.uk)

DESCRIPTION	ISSUE	DATE	DRAWN	CHECKED	DRAWING NUMBER
Moving coil step up transformer ground (1) (PCB mounting)	1	05/02/13	CS		<b>A187A16C/1</b>
	6	22/03/17	CS		
	7	08/01/19	CS		
	8	08/02/24	CS		
Scale: nts	All dimensions in mm unless stated otherwise				

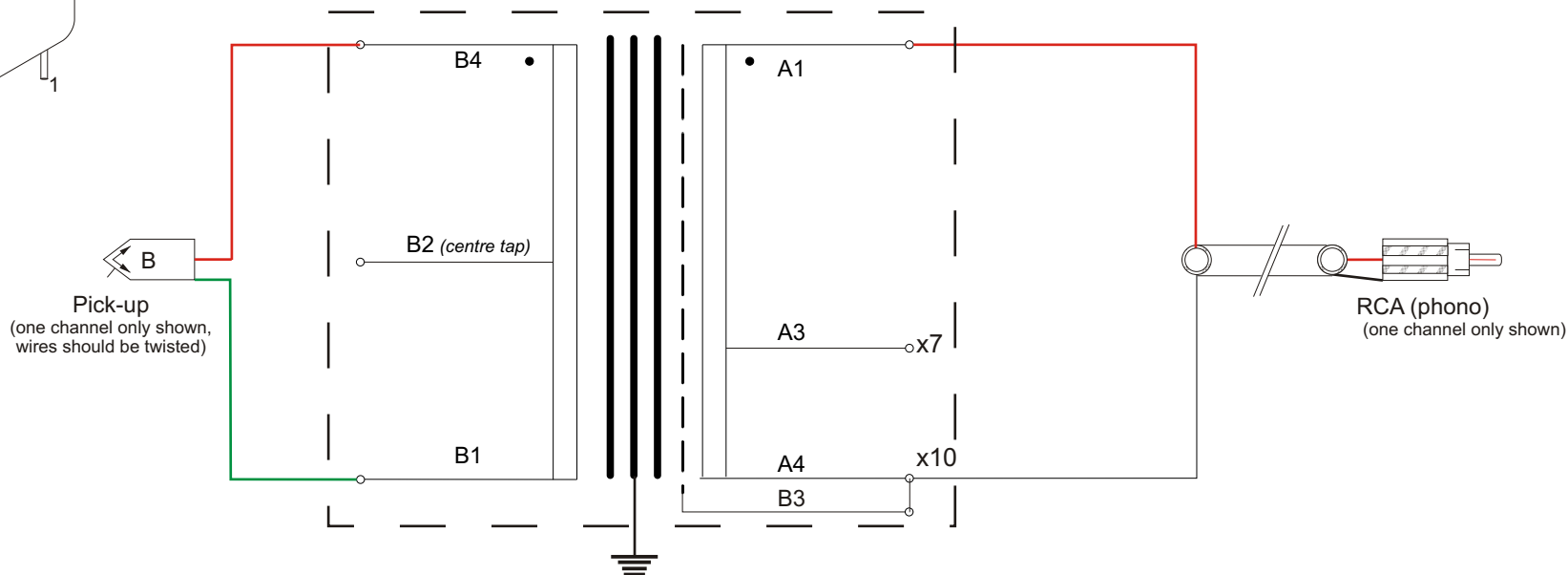
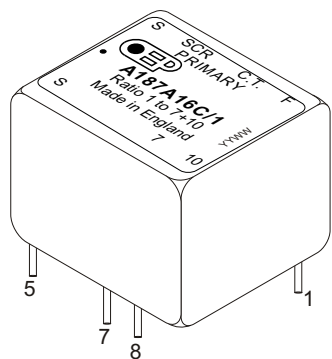

**Notes:**

- Ground screen (B3) and screening can to output. If tonearm has separate ground, link to screening can
- Do not connect input to chassis ground
- Unused pins should be left floating with minimal pad size for best performance.
- All leads should be as short as possible.
- Pick-up leads should be twisted tightly.
- Two transformers are required for stereo
- Lead colours should be checked with cartridge manufacturer

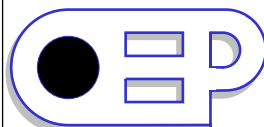

Unit 5, Oxonian Park, Langford Locks,  
Kidlington, Oxfordshire. OX5 1FP  
Tel: (01865) 855085 Fax: (01865) 855075  
Website: [www.carnhill.co.uk](http://www.carnhill.co.uk)

DESCRIPTION	ISSUE	DATE	DRAWN	CHECKED	DRAWING NUMBER
Moving coil step up transformer, ground (2) (PCB mounting)	1	05/02/13	CS		<b>A187A16C/1</b>
	6	22/03/17	CS		
	7	08/01/19	CS		
	8	08/02/24	CS		
Scale: nts	All dimensions in mm unless stated otherwise				

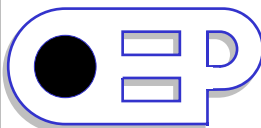
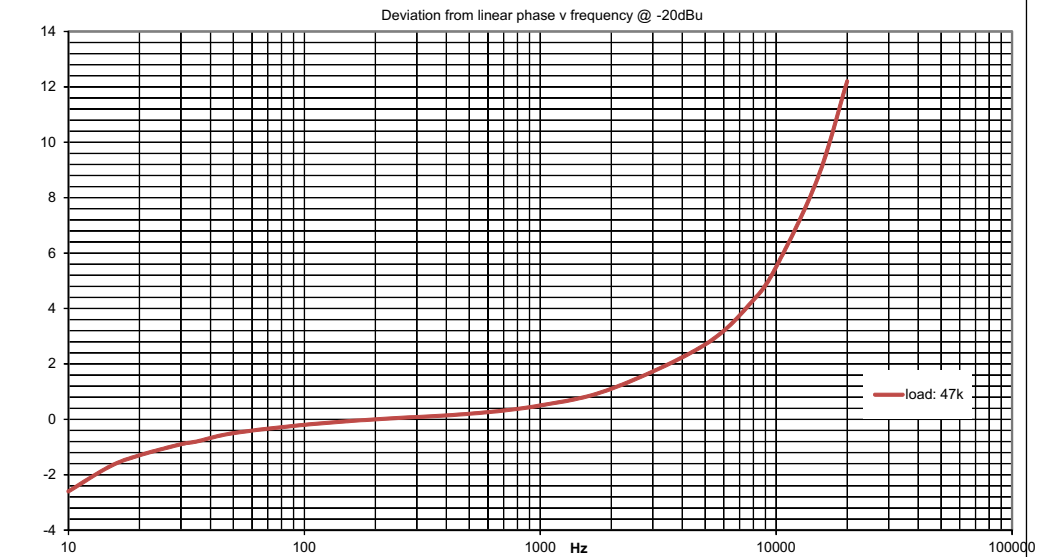
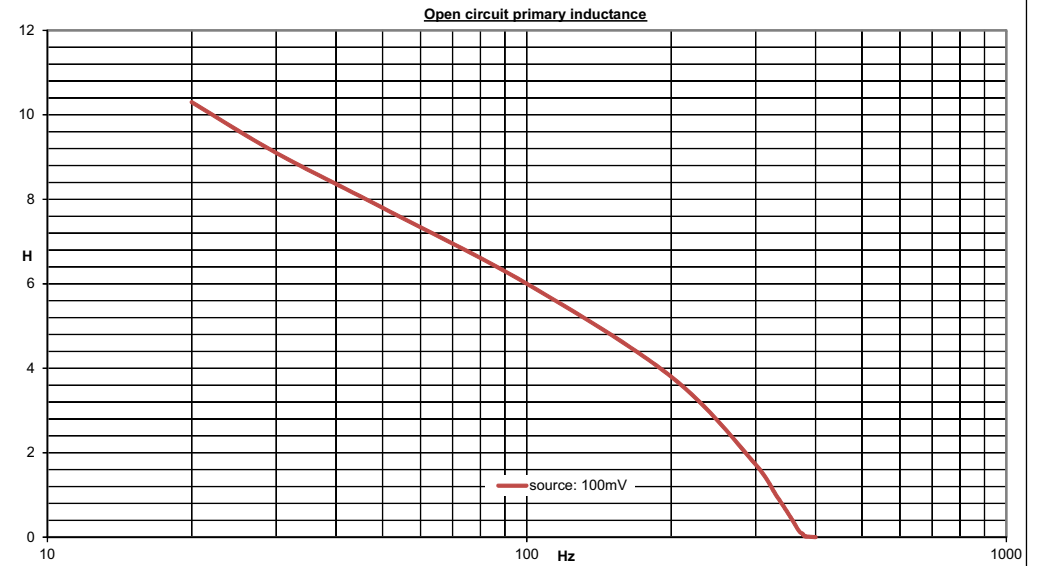
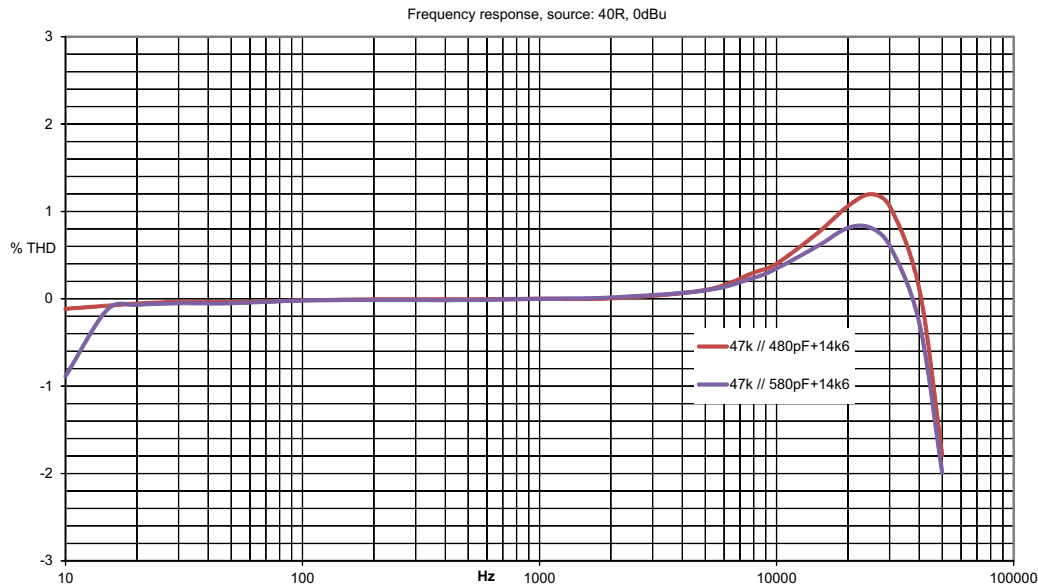

Unit 5, Oxonian Park, Langford Locks,  
Kidlington, Oxfordshire. OX5 1FP  
Tel: (01865) 855085 Fax: (01865) 855075  
Website: [www.carnhill.co.uk](http://www.carnhill.co.uk)

DESCRIPTION	ISSUE	DATE	DRAWN	CHECKED	DRAWING NUMBER
1C.T. to 7+10 moving coil phono cartridge step up transformer (PCB mounting)	1	05/02/13	CS		<b>A187A16C/1</b>
	6	22/03/17	CS		
	7	08/01/19	CS		
	8	08/02/24	CS		
Scale: nts	All dimensions in mm unless stated otherwise				